

ITEM NO.	QTY.	PART NUMBER	DESCRIPTION
1	1	2419	BASE-SHELF
2	2	2418	BASE-SIDE PANEL
3	16	2419-H	1/4-20 X 3/8" HEX HEAD CAP SCREW
4	8	PEM S-0420-1-Z1	PEM NUT 1/4-20 (PEM S-0420-1-Z1) MIN SHT THK .056

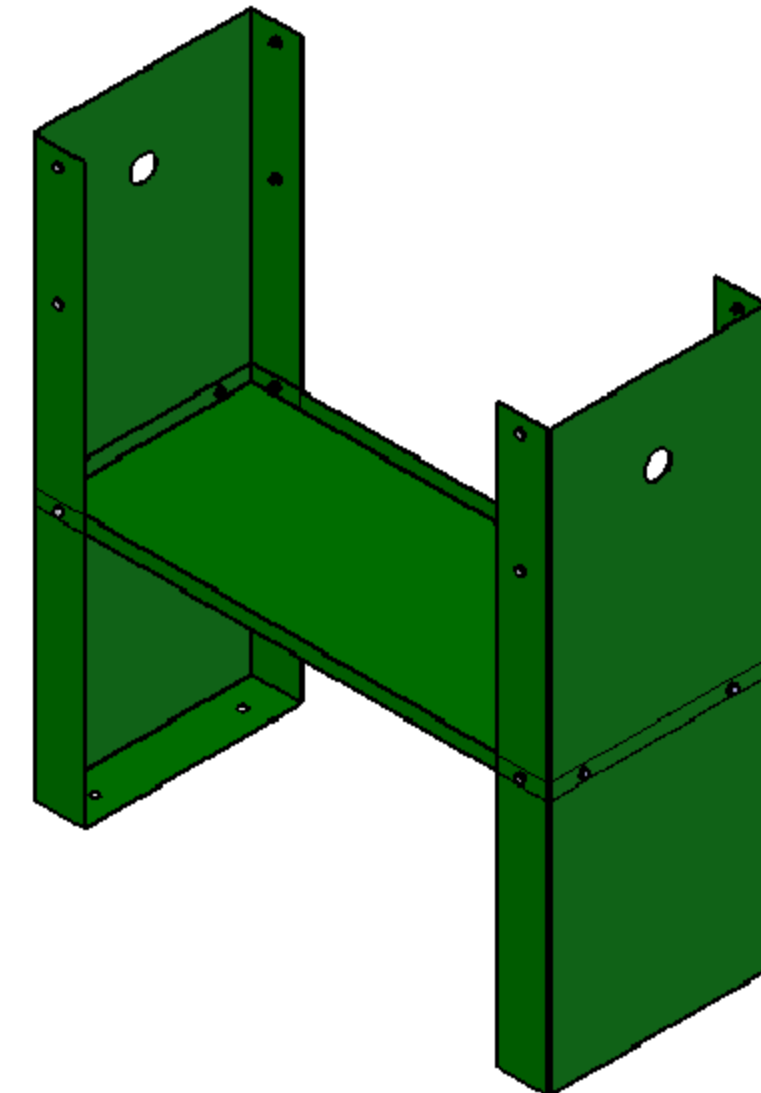
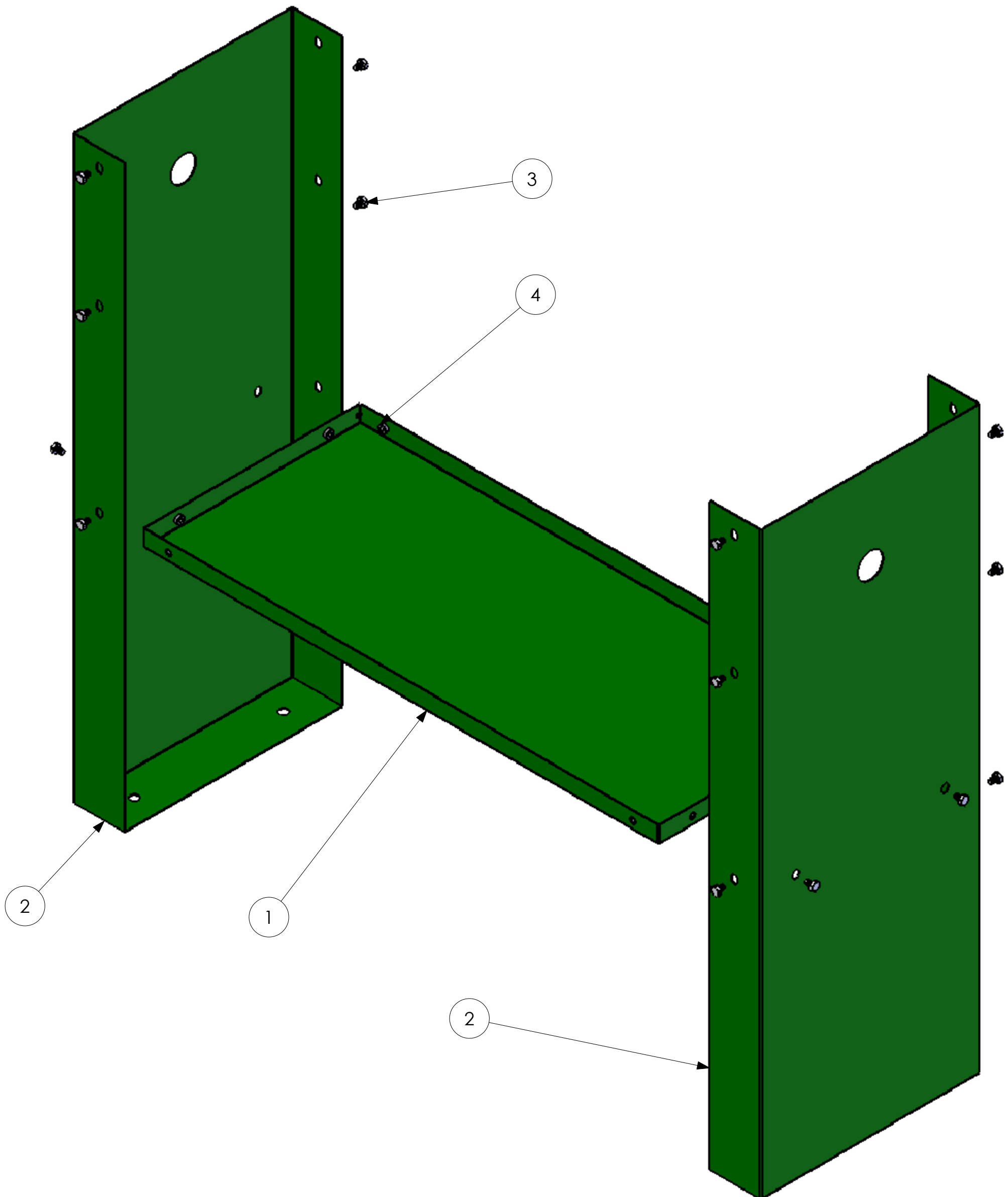

PITTSBURGH MACHINE

DIMENSIONS ARE IN INCHES
TOLERANCES:
FRACTIONAL ± 1/16
ANGULAR: MACH ± BEND ±
TWO PLACE DECIMAL ±.01
THREE PLACE DECIMAL ±.005

THE INFORMATION CONTAINED IN THIS DRAWING IS THE SOLE PROPERTY OF HORIZON SYSTEMS MACHINING. ANY REPRODUCTION IN PART OR AS A WHOLE WITHOUT THE WRITTEN PERMISSION OF HORIZON SYSTEMS MACHINING IS PROHIBITED.

	NAME	DATE
DRAWN	KRB	01-10-05
CHECKED		
ENG APPR.		
MFG APPR.		
Q.A.		

HORIZON SYSTEMS MACHINING
9121 58TH PLACE
KENOSHA, WI 53144
PH: 262-605-1122
FAX: 262-605-1198

MATERIAL
16GA STEEL
FINISH
PAINTED
DO NOT SCALE DRAWING

TITLE: PITTSBURGH STAND	
SIZE C	DWG. NO. RAMS-2428-S
SCALE: 1:1	REV SHEET 1 OF 1